

8 7 6 5 4 3 2 1

REVISIONS				
ZONE	REV.	DESCRIPTION	DATE	APPROVED
	A	Check-In	11/29/2011	MAM

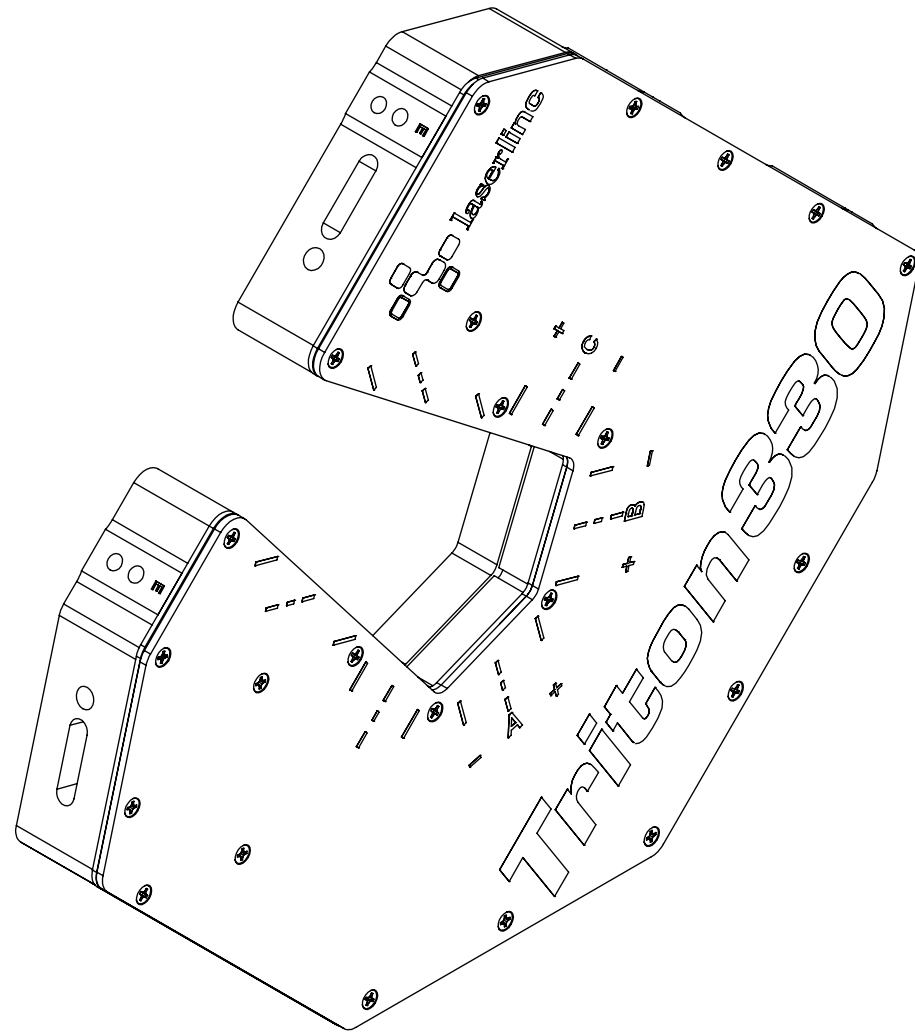

Triton330 Overall Mount Dimensions

INDEX

- (1) Cover Page
- (2) Back & A-Mounting Dimensions
- (3) B-Mounting Dimensions
- (4) C-Mounting Dimensions
- (5) D-Mounting Dimensions
- (6) E-Mounting Dimensions

UNLESS OTHERWISE SPECIFIED:		NAME	DATE
DIMENSIONS ARE IN INCHES		DRAWN BY:	MAM 11/29/2011
TOLERANCES:			
ANGULAR: MACH ± BEND ±			
TWO PLACE DECIMAL ±0.010			
THREE PLACE DECIMAL ±0.005			
FOUR PLACE DECIMAL ±0.0005			
ANGLES ±2°			
UNMARKED FILLETS/ROUNDS R.0625			
DE-BURR ALL PARTS			
INTERPRET GEOMETRIC TOLERANCING PER:		63 RA SURFACE FINISH ALL FEATURES MUST MEET SPECIFICATION AFTER PLATING BEFORE POWDER-COAT IF PLATED OR POWDER-COATED SEE FINISH MACHINE ALL SURFACES	
MATERIAL			
FINISH			
DO NOT SCALE DRAWING			
<p>PROPRIETARY AND CONFIDENTIAL</p> <p>THE INFORMATION CONTAINED IN THIS DRAWING IS THE SOLE PROPERTY OF LASERLINC, INC. ANY REPRODUCTION IN PART OR AS A WHOLE WITHOUT THE WRITTEN PERMISSION OF LASERLINC, INC IS PROHIBITED.</p>		 <p>LaserLinc, Inc. Phone: 888-707-4892 Info@laserlinc.com www.laserlinc.com</p>	
TITLE: 00330-01 Triton330 Overall Mount Dimensions			
SIZE	DWG. NO.	REV	
B	00330-01	A	
SCALE: 1:1		SHEET 1 OF 6	

8 7 6 5 4 3 2 1

D
C
B
A

D
C
B
A

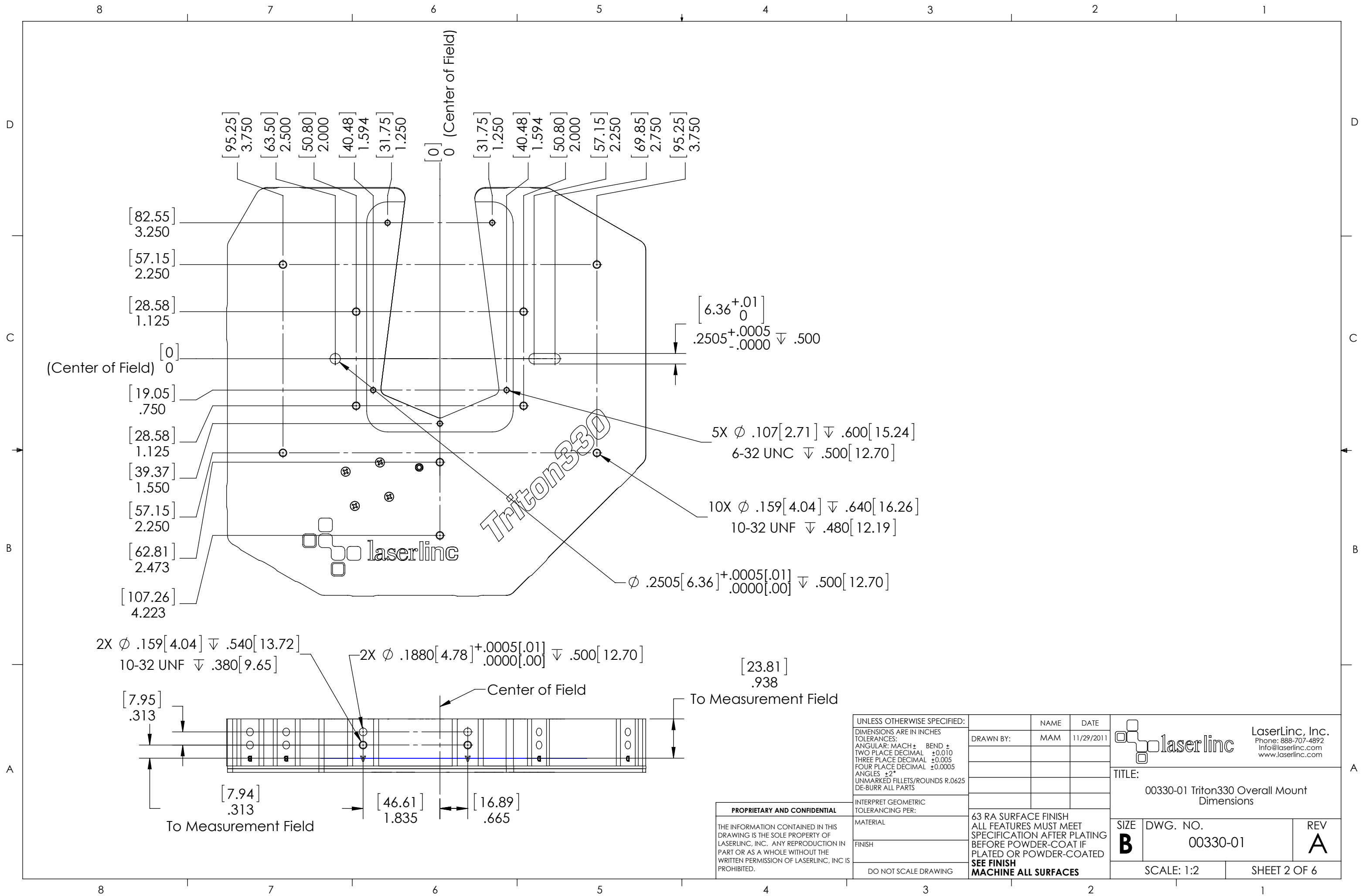

UNLESS OTHERWISE SPECIFIED:
 DIMENSIONS ARE IN INCHES
 TOLERANCES:
 ANGULAR: MACH \pm BEND \pm
 TWO PLACE DECIMAL ± 0.010
 THREE PLACE DECIMAL ± 0.005
 FOUR PLACE DECIMAL ± 0.0005
 ANGLES $\pm 2^\circ$
 UNMARKED FILLETS/ROUNDS R.0625
 DE-BURR ALL PARTS

DRAWN BY:	NAME	DATE
	MAM	11/29/2011

laserline LaserLinc, Inc.
 Phone: 888-707-4892
 Info@laserline.com
 www.laserline.com

TITLE:
 00330-01 Triton330 Overall Mount
 Dimensions

PROPRIETARY AND CONFIDENTIAL
 THE INFORMATION CONTAINED IN THIS
 DRAWING IS THE SOLE PROPERTY OF
 LASERLINC, INC. ANY REPRODUCTION IN
 PART OR AS A WHOLE WITHOUT THE
 WRITTEN PERMISSION OF LASERLINC, INC IS
 PROHIBITED.

INTERPRET GEOMETRIC TOLERANCING PER:	63 RA SURFACE FINISH ALL FEATURES MUST MEET SPECIFICATION AFTER PLATING BEFORE POWDER-COAT IF PLATED OR POWDER-COATED SEE FINISH MACHINE ALL SURFACES
MATERIAL	
FINISH	

SIZE B	DWG. NO. 00330-01	REV A
SCALE: 1:2		SHEET 2 OF 6

DO NOT SCALE DRAWING

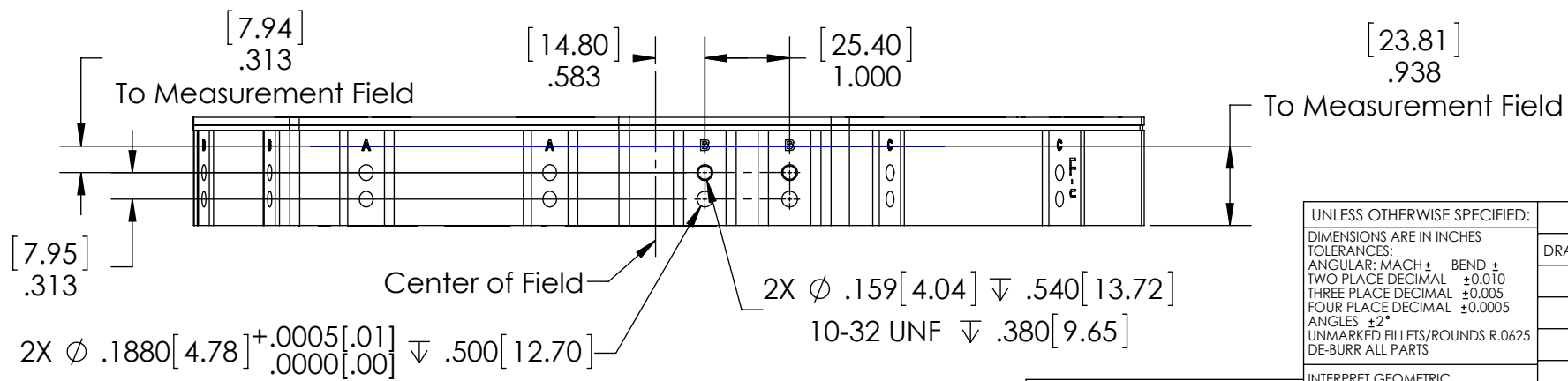
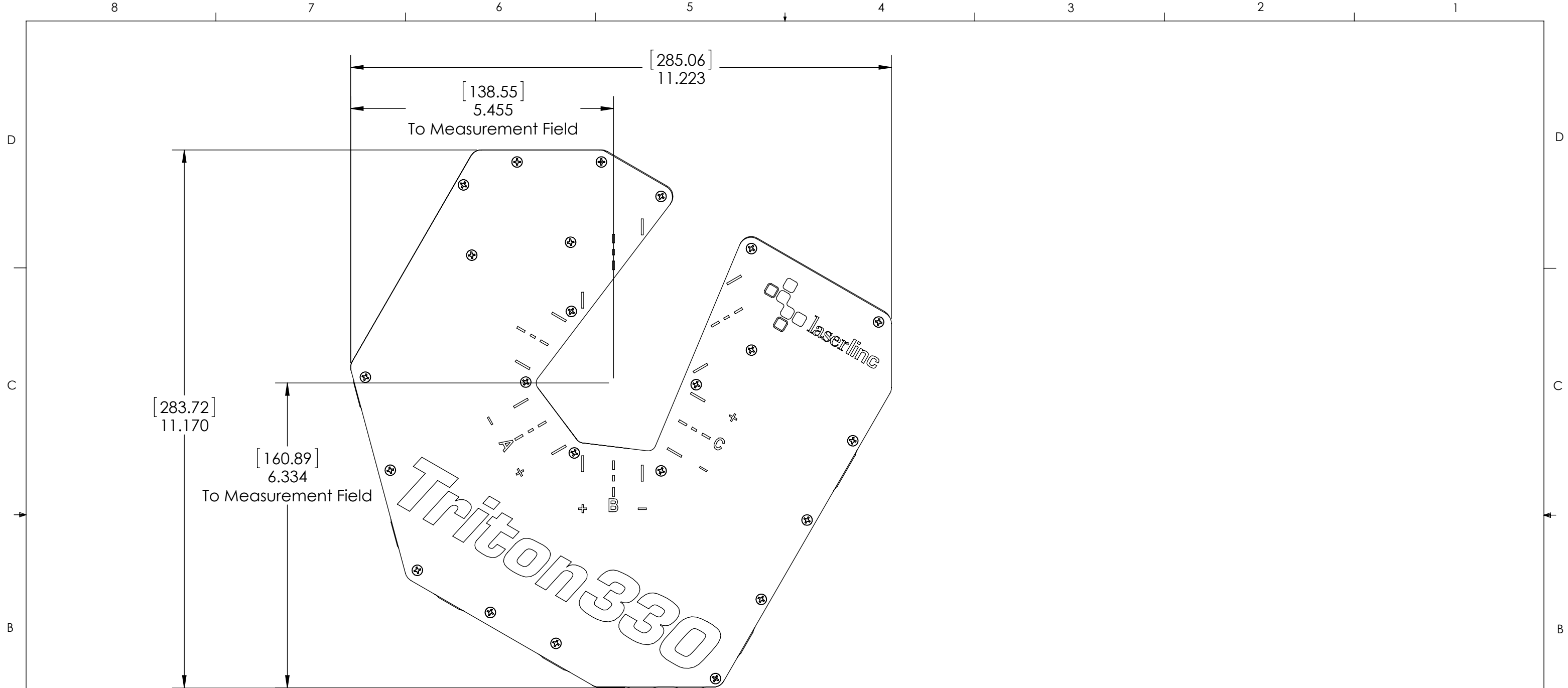

UNLESS OTHERWISE SPECIFIED:
 DIMENSIONS ARE IN INCHES
 TOLERANCES:
 ANGULAR: MACH ± BEND ±
 TWO PLACE DECIMAL ±0.010
 THREE PLACE DECIMAL ±0.005
 FOUR PLACE DECIMAL ±0.0005
 ANGLES ±2°
 UNMARKED FILLETS/ROUNDS R.0625
 DE-BURR ALL PARTS

NAME	DATE
MAM	11/29/2011

laserline LaserLinc, Inc.
 Phone: 888-707-4892
 Info@laserline.com
 www.laserline.com

TITLE:
 00330-01 Triton330 Overall Mount
 Dimensions

PROPRIETARY AND CONFIDENTIAL
 THE INFORMATION CONTAINED IN THIS
 DRAWING IS THE SOLE PROPERTY OF
 LASERLINC, INC. ANY REPRODUCTION IN
 PART OR AS A WHOLE WITHOUT THE
 WRITTEN PERMISSION OF LASERLINC, INC IS
 PROHIBITED.

INTERPRET GEOMETRIC TOLERANCING PER:
MATERIAL
FINISH
DO NOT SCALE DRAWING

63 RA SURFACE FINISH
 ALL FEATURES MUST MEET
 SPECIFICATION AFTER PLATING
 BEFORE POWDER-COAT IF
 PLATED OR POWDER-COATED
**SEE FINISH
 MACHINE ALL SURFACES**

SIZE	DWG. NO.	REV
B	00330-01	A

SCALE: 1:2 SHEET 3 OF 6

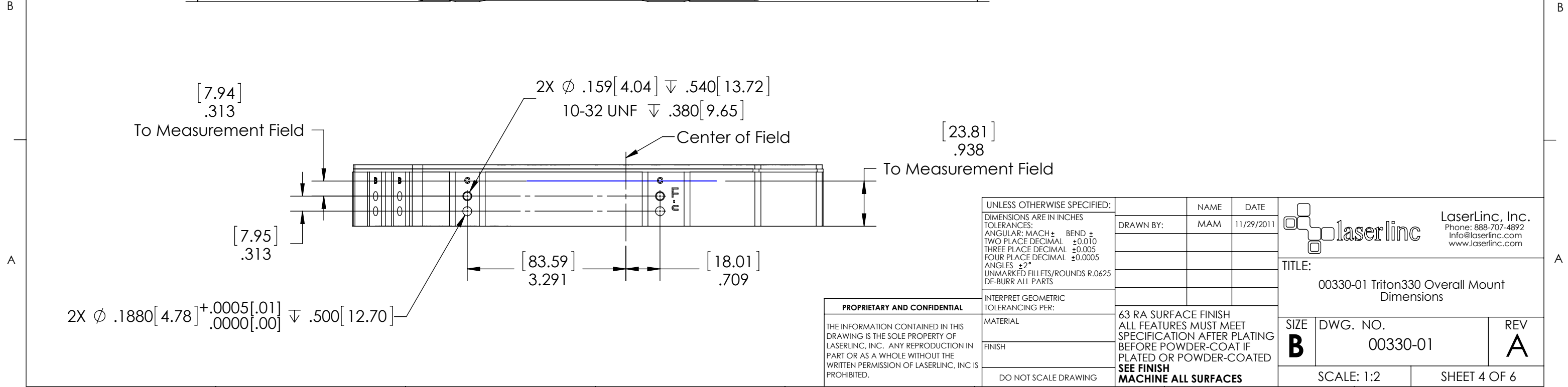
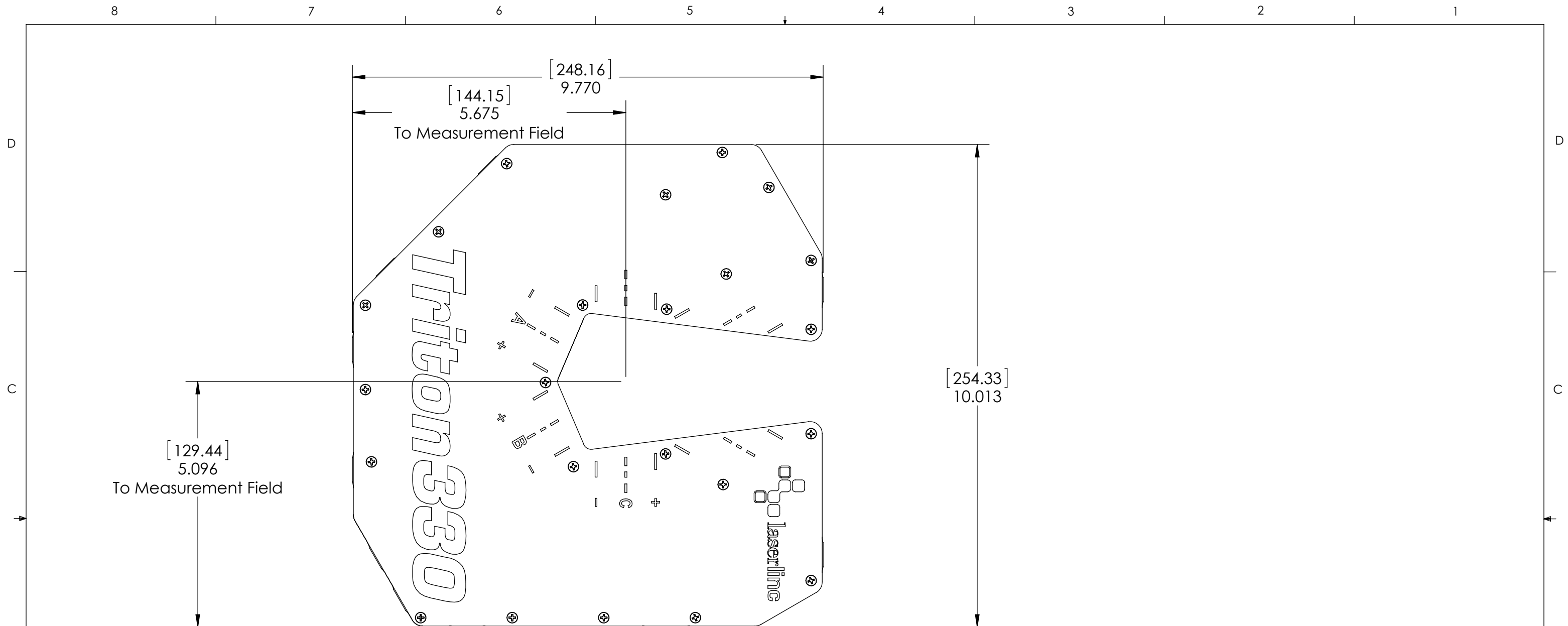

UNLESS OTHERWISE SPECIFIED:		NAME	DATE
DIMENSIONS ARE IN INCHES		DRAWN BY:	MAM 11/29/2011
TOLERANCES:			
ANGULAR: MACH ± BEND ±			
TWO PLACE DECIMAL ±0.010			
THREE PLACE DECIMAL ±0.005			
FOUR PLACE DECIMAL ±0.0005			
ANGLES ±2°			
UNMARKED FILLETS/ROUNDS R.0625			
DE-BURR ALL PARTS			
INTERPRET GEOMETRIC TOLERANCING PER:		LaserLinc, Inc. Phone: 888-707-4892 Info@laserlinc.com www.laserlinc.com	
MATERIAL		TITLE: 00330-01 Triton330 Overall Mount Dimensions	
FINISH		SIZE B	DWG. NO. 00330-01
DO NOT SCALE DRAWING		SCALE: 1:2	REV A
		SHEET 4 OF 6	

PROPRIETARY AND CONFIDENTIAL

THE INFORMATION CONTAINED IN THIS DRAWING IS THE SOLE PROPERTY OF LASERLINC, INC. ANY REPRODUCTION IN PART OR AS A WHOLE WITHOUT THE WRITTEN PERMISSION OF LASERLINC, INC IS PROHIBITED.

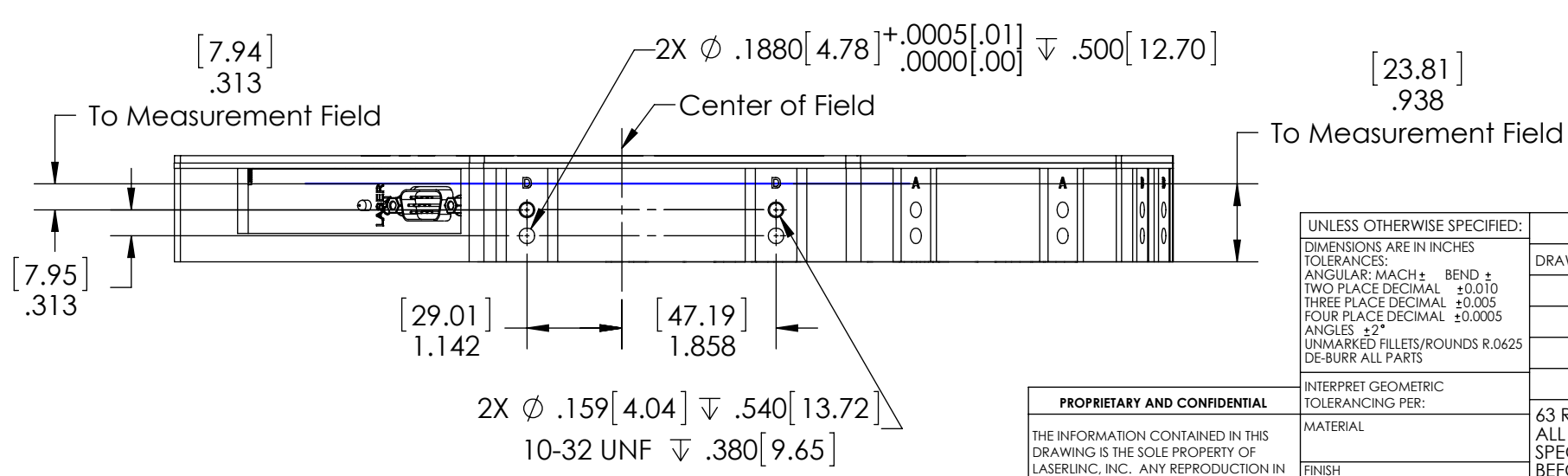
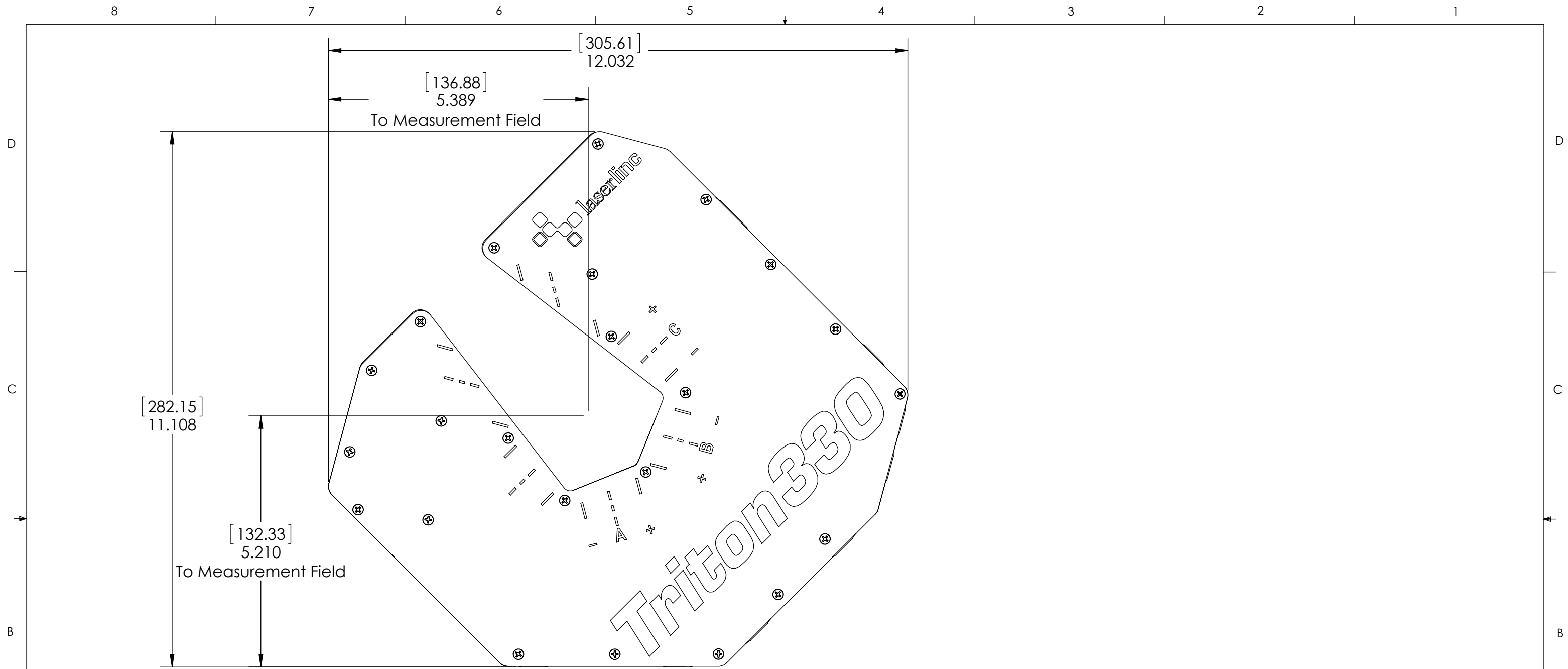

UNLESS OTHERWISE SPECIFIED: DIMENSIONS ARE IN INCHES TOLERANCES: ANGULAR: MACH ± BEND ± TWO PLACE DECIMAL ±0.010 THREE PLACE DECIMAL ±0.005 FOUR PLACE DECIMAL ±0.0005 ANGLES ±2° UNMARKED FILLETS/ROUNDS R.0625 DE-BURR ALL PARTS	NAME	DATE	 LaserLinc, Inc. Phone: 888-707-4892 Info@laserlinc.com www.laserlinc.com	
	DRAWN BY:	MAM		11/29/2011
	TITLE:	00330-01 Triton330 Overall Mount Dimensions		
	SIZE	DWG. NO.		REV
PROPRIETARY AND CONFIDENTIAL THE INFORMATION CONTAINED IN THIS DRAWING IS THE SOLE PROPERTY OF LASERLINC, INC. ANY REPRODUCTION IN PART OR AS A WHOLE WITHOUT THE WRITTEN PERMISSION OF LASERLINC, INC IS PROHIBITED.	INTERPRET GEOMETRIC TOLERANCING PER: MATERIAL FINISH DO NOT SCALE DRAWING	63 RA SURFACE FINISH ALL FEATURES MUST MEET SPECIFICATION AFTER PLATING BEFORE POWDER-COAT IF PLATED OR POWDER-COATED SEE FINISH MACHINE ALL SURFACES	SCALE: 1:2 SHEET 5 OF 6	

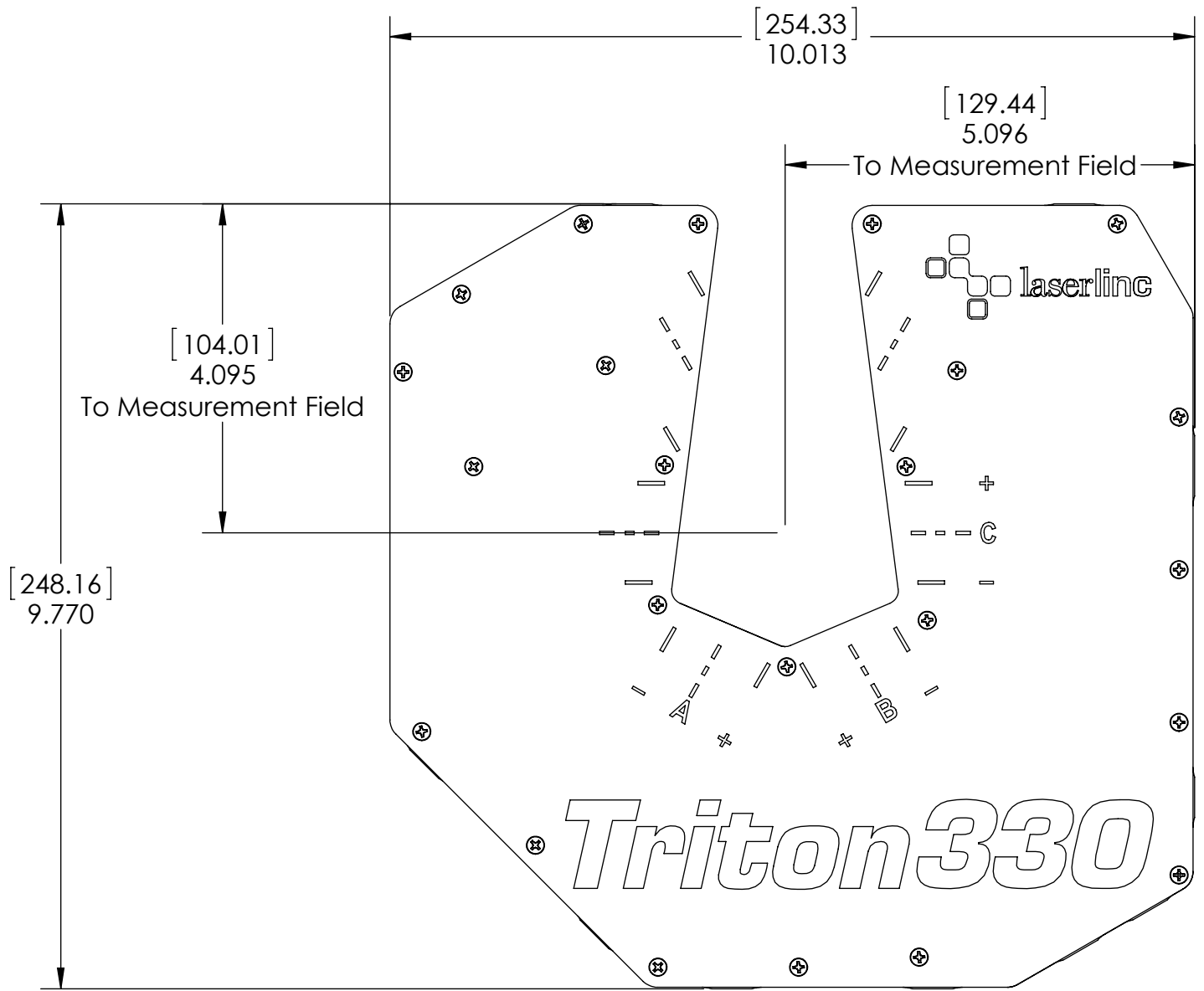
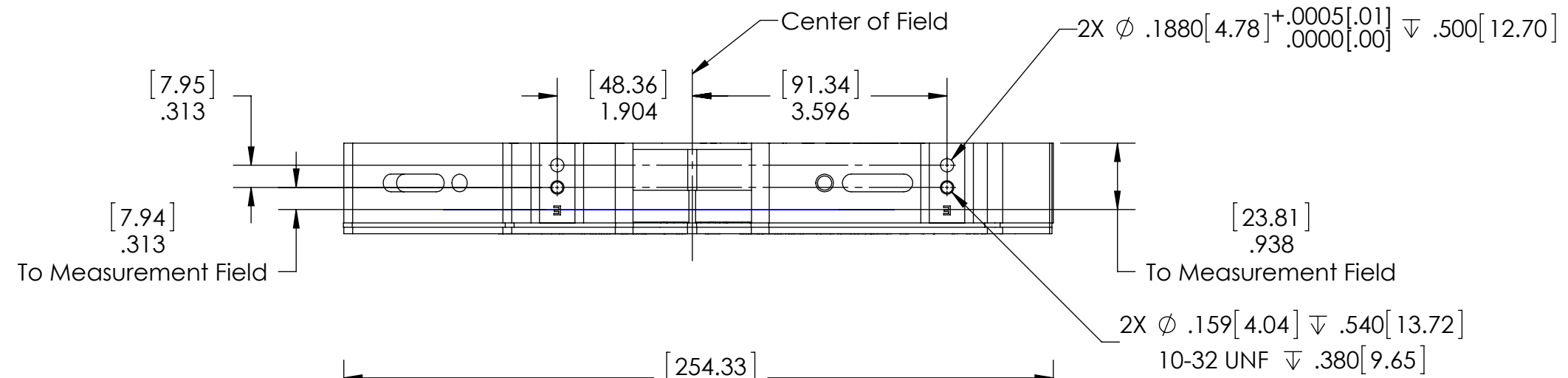

UNLESS OTHERWISE SPECIFIED:		NAME	DATE
DIMENSIONS ARE IN INCHES		DRAWN BY:	MAM 11/29/2011
TOLERANCES:			
ANGULAR: MACH ± BEND ±			
TWO PLACE DECIMAL ±0.010			
THREE PLACE DECIMAL ±0.005			
FOUR PLACE DECIMAL ±0.0005			
ANGLES ±2°			
UNMARKED FILLETS/ROUNDS R.0625			
DE-BURR ALL PARTS			
INTERPRET GEOMETRIC TOLERANCING PER:			
MATERIAL		63 RA SURFACE FINISH	
FINISH		ALL FEATURES MUST MEET SPECIFICATION AFTER PLATING BEFORE POWDER-COAT IF PLATED OR POWDER-COATED	
DO NOT SCALE DRAWING		SEE FINISH MACHINE ALL SURFACES	

PROPRIETARY AND CONFIDENTIAL

THE INFORMATION CONTAINED IN THIS DRAWING IS THE SOLE PROPERTY OF LASERLINC, INC. ANY REPRODUCTION IN PART OR AS A WHOLE WITHOUT THE WRITTEN PERMISSION OF LASERLINC, INC IS PROHIBITED.

laserline LaserLinc, Inc.
 Phone: 888-707-4892
 Info@laserlinc.com
 www.laserlinc.com

TITLE: 00330-01 Triton330 Overall Mount Dimensions		
SIZE B	DWG. NO. 00330-01	REV A
SCALE: 1:2		SHEET 6 OF 6